

Scrutinizing the details to minimize the risk of washdown motor ingress

A bottom-line factor for food processing operations



A REGAL REYNOLD BRAND

Electric motors in food processing washdown environments face a challenging existence. The FDA has aggressive standards for washdown and equipment sanitation in food production, so motors endure frequent high-temperature, high-pressure spraying, often with caustic cleaning solutions containing citric acid, chlorine, or even diluted hydrochloric acid.

Maintaining these motors is even more challenging when they are mounted in a variety of positions along the line. Identical motors can experience harsher or less harsh washdown conditions depending on the positions in which they're installed, with corresponding differences in maintenance needs and longevity.

And motor longevity is a critical bottom-line factor for food processing operations. With every minute of downtime causing lost revenue, it's essential to keep motors at continuous, full capacity for as long as possible.

The most significant contributor to washdown motor failure is ingress. Any ingress of water, chemicals, or debris can lead to corrosion, which can damage a motor and quickly bring a production line to a halt.

This white paper will review the maintenance challenges of food processing facilities, assess common manufacturing steps that limit ingress, and focus on innovative designs that prevent ingress and extend the lifetime of washdown motors.

Downtime can be devastating

Avoiding unexpected downtime is critical to running an efficient processing line, and the reliability of the electric motors running that line plays a key role in keeping things moving.

With an estimated cost of \$500 per minute and a common motor replacement time of 10-15 minutes, a single failure can cost **\$5,000-\$7,500.***



The inherent maintenance challenges of food processing facilities

Equipment maintenance is more difficult in food processing than in other industries due to conditions and challenges such as extreme temperatures, dust, and long hours. Plus, food processing facilities have to meet aggressive FDA standards for washdown and equipment sanitation that don't apply to other industries, so motors are at even greater risk of ingress.

Yet food production has the same need for uptime as other industries, which drives operations to increase the speed of their maintenance work — 67% of food and beverage manufacturing leaders rank maintenance system improvement among their top productivity needs.¹ Unfortunately, increased speed of maintenance can sometimes result in issues being overlooked, resulting in unexpected downtime.

Food processing facilities also face difficulties retaining skilled maintenance staff. While 55% of food manufacturing leaders say their organizations are adding on-the-job training for maintenance workers,² it's simply a reality that many workers don't stay on the job long enough for training to significantly elevate an organization's overall maintenance skill levels.

Even for dedicated, long-term staff, food production machine maintenance is a physically demanding job in a harsh, unpleasant environment — especially when meat or poultry are involved. No one wants to spend more time at it than necessary, which can lead to maintenance lapses that let small issues become large problems.

All these factors magnify the importance of longevity for washdown motors. Preventing downtime in the severe environment of a food processing plant — and protecting an operation's bottom line — means protecting motors from ingress however possible.

How motor manufacturers design against ingress

Motor manufacturers have introduced several innovations over the years to extend the life of food manufacturing motors and limit ingress.

- **Stainless steel exteriors**

Cast iron or aluminum motor housings and frames will quickly corrode in a washdown environment without the protection of an epoxy paint or powder coating, but even those barriers can't withstand the high-pressure water and caustic cleaning over the long run. That's why manufacturers have made stainless steel the material of choice due to its inherent corrosion resistance and ability to hold tight welds at the seams.

- **Shaft seals**

Even with a rugged stainless-steel exterior, there's an obvious ingress point where the rotating motor shaft exits the housing and connects to whatever the motor is driving. Most manufacturers address this ingress point with multiple shaft seals.

- **Sealed conduit boxes**

The conduit box where the electrical supply for the motor enters is another obvious ingress point. It's usually addressed with O-rings, but O-rings must be fully engaged and compressed to provide maximum protection. They also deteriorate over time.

Despite these advances in motor protection, washdown motors can still be vulnerable to ingress through improper installation or maintenance.

Addressing potential ingress through conduit lines

Regardless of a motor's features, ingress can happen through the conduit if the connections and cutoff boxes aren't properly installed and maintained. Engineers have made these connections easier to install and maintain, but operations still must attend closely to these details.

- **Conduit box connections**

These connections must be tight at the National Pipe Tapered (NPT) connection point to prevent water from traveling down the outside of the conduit into the conduit box, and the O-rings must be properly compressed. Also, some motors are equipped with a conduit box hold-down clamp that allows the box to be rotated, and it must also be tightened adequately to prevent ingress.

- **Disconnect boxes**

These enclosures must be properly sealed with all screws, sealing washers, and gaskets in place and in good condition to prevent water traveling inside the conduit and reaching the motor. Also, engineers have determined that mounting disconnect boxes level with or below the motor provides an extra measure of protection, because any liquids that do permeate the disconnect box will funnel away from the motor instead of downward into the housing.

IP ratings

The National Electrical Manufacturers Association (NEMA) has adopted the International Electrotechnical Commission (IEC) standards and test procedures to determine ingress protection (IP) for enclosures. The IP rating consists of the letters IP followed by two numbers — a rating from 0-6 indicating protection against particulate solids, such as dust, and a second rating from 0-9 indicating protection against liquids. Finally, a "K" signifies protection against high-pressure, high-temperature water jets.

An IP69K rating indicates the ultimate ingress protection for the most extreme applications.

Against particulate solids

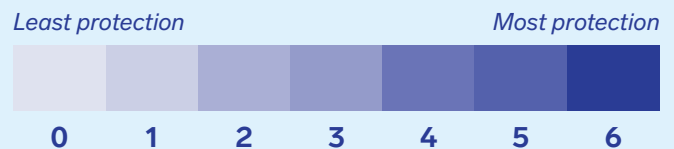

Against liquids

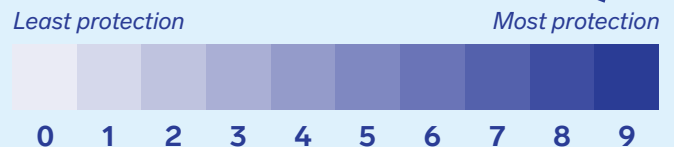

A new standard for ingress protection

Engineers set out to address every possible point of ingress in washdown motors, and their innovations have established a new standard for ingress protection: the LEESON Extreme Duck® Ultra.

1. Encapsulated body

Since drain plugs and breathers can be ingress points, LEESON engineers encapsulated the entire body assembly — including the end bells — with a proprietary epoxy using a vacuum assist. Eliminating any air pockets where condensation could occur also eliminated the need for drain plugs and breathers, making the housing completely impervious.

2. Sealing around rotating shafts

Instead of using multiple seals, LEESON engineers employed a new type of two-piece shaft seal with a flinger that provided three points of protection from water, oil, and chemicals. It also ensured the motor could be installed in any orientation with the same level of protection. This proprietary seal shaft underwent a year of testing — 8,760 hours — before the system was released for third-party IP evaluation.

3. Q-Car™ rotor cartridge

Once enclosed, the completely impervious windings incorporated an exclusive Q-Car™ rotor cartridge, which allows the replacement of the rotor assembly — bearings, rotor, shaft, and seals — in four easy steps, simplifying maintenance without compromising ingress protection.

4. Conduit box innovations

Since O-rings deteriorate, LEESON engineers replaced them with a welded pipe nipple at the conduit ingress that eliminated the need for an O-ring. And at the conduit itself, the engineers eliminated the most common field failure with non-wicking leads directly in the motor. The conduit box itself has a special mounting clamp design so it can be rotated a full 360 degrees for convenient cable entry.

To put these innovations to the test, the LEESON Extreme Duck® Ultra was submitted for independent testing to earn the highest possible rating: IP69K. This certification would establish the Extreme Duck Ultra as ideal for conditions — such as those found in food manufacturing — where equipment must be carefully sanitized and withstand rigorous washdown procedures.

- **Dust resistance testing:** Seams were tested with a 1 mm wire test probe, and then the motor was placed in a test chamber filled with blowing talcum powder or alum dust (particles as small as 0.5 microns). The motor was subjected to a vacuum of up to 20 mbar for up to eight hours while inside the test chamber. Upon disassembly, no evidence of dust ingress was found in the motor. It was dust tight.
- **Fluid protection testing:** The motors were placed on turntables at 4-6 RPM. They were then continuously sprayed with scalding water of a temperature of 176°F (80°C) at a pressure of 1,160-1,450 PSI for a minimum of three minutes — from just 4-6 inches away — until the entire surface of the motor had been sprayed. The motors were fully disassembled and examined for any evidence of fluid penetration or residual moisture from steam. None was found.

Testing proved that the LEESON Extreme Duck® Ultra had earned an IP69K rating. This motor has also been issued patents for its encapsulated sealing and the QCar rotor cartridge. It is as close as a motor can be to 100% ingress-free.

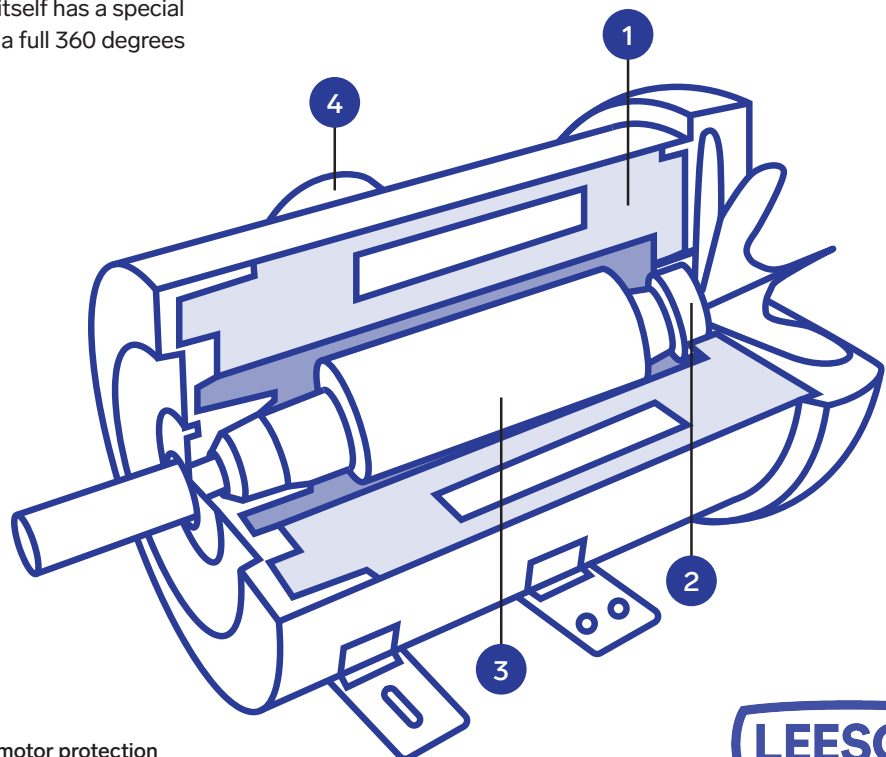

A holistic approach
to ingress protection

Extreme
DUCK ULTRA

Motors for less demanding environments

Not every environment is as harsh as a food processing plant, and not every motor needs an IP69K rating. Other LEESON motors may be excellent fits for particular environments.

Premium Duck™ Motors



With IP56 enclosure protection, this washdown duty motor is perfect for clean room and severe chemical-processing applications involving frequent motor washdown with nitric acid and caustic lye. Its ideal applications include pharmaceutical, food processing, dairy, chemical processing, beverage, and bottling.

SST Duck™ Motors



The SST Duck™ Wash Down Duty® motors are designed for ultra-clean operations where a paint-free motor is needed. All stainless-steel external components withstand the severe environments found in food and beverage processing as well as pharmaceutical or chemical processing.

Washguard® II Motors



Washguard® II motors are well-suited for the demanding environments of bakeries and food processing facilities requiring frequent sanitation using high-pressure cleaning with concentrated caustic solutions, areas of high humidity, as well as chemical environments.

White Duck™ Motors



White Duck motors are designed for an occasional washdown. Coated in a high-gloss, high-durability, USDA-approved white epoxy finish, White Duck washdown motors are a perfect fit in conveying, bottling, food packaging, pumping and fan applications.

*Downtime cost estimates and case study results are based on Regal Rexnord data. Please contact us for complete documentation.

1—Food Manufacturing, “The State of Food Manufacturing in 2023”

2—Food Processing, “2024 Manufacturing Survey Results: Riding the Roller Coaster”

Talk to a LEESON expert about improving the longevity of the electric motors on your food processing line.



Regal Rexnord
[regalrexnord.com/leeson](https://www.regalrexnord.com/leeson)

Power Efficiency Solutions
1051 Cheyenne Ave.
Grafton, WI 53024
262-377-8810

The proper selection and application of products and components, including assuring that the product is safe for its intended use, are the responsibility of the customer. To view our Application Considerations, please visit <https://www.regalrexnord.com/Application-Considerations>

To view our Standard Terms and Conditions of Sale, please visit www.regalrexnord.com/Terms-and-Conditions-of-Sale

"Regal Rexnord" is not indicative of legal entity. Refer to product purchase documentation for the applicable legal entity. Regal Rexnord®, LEESON®, Extreme Duck®, Premium Duck™, SST Duck™, Washguard™, White Duck™, and Q-Car™ are trademarks of Regal Rexnord Corporation or one of its affiliated companies. The following are believed to be the trademark and/or trade name of their respective owners and are not owned or controlled by Regal Rexnord Corporation. FDA: Food and Drug Administration, NEMA: National Electrical Manufacturers Association, IEC: International Electrotechnical Commission.